

AdaxGW: Multi-Purpose Gateway for 4G/LTE, NGMN, Legacy & IMS Networks



Overview

Today's wireless applications demand higher bandwidth from the network and to meet this challenge new LTE technologies are being developed. Network Service Providers are making the migration to LTE but the All-IP network will be a while in the making. Legacy connectivity for voice and SMS will remain an absolute requirement for next generation network nodes connecting IP-based or IP-enabled Media Gateways, Signaling Transfer Points, switches, databases and other Next Generation Mobile applications with legacy circuit switched architecture. This need to interconnect different networks demands multi-protocol solutions that combine and connect divergent circuit and packet switching architectures. In addition, there are new possibilities for replacing expensive dedicated SS7 and ATM circuits with more cost effective IP links.

The AdaxGW

The Adax Gateway (AdaxGW) addresses all of these requirements and more. The link density, scalability, flexibility, throughput, High-Availability and high performance of the AdaxGW enables operators to manage the convergence and growth of their networks, maximize revenues, satisfy consumer demands for new services and ultimately protect their investment in both traditional signaling and new IP networks.

User plane services have been added to the AdaxGW with the use of the Adax ATCA/AMC hardware; Adax PacketRunner hosting the PktAMC, ATM4-AMC and HDC3-AMC. The PktAMC supports packet processing intensive applications such as RTP via the Adax software module *ethfilt*. The ATM4 provides ATM-IP interworking as well as AAL5 signaling termination. UDP/IP packets are sent to the PktAMC for RTP processing on to the IP network. The HDC3-AMC provides I-TDM interworking along with SS7 LSLs, Annex A and ATM T1/E1 High Speed Links. The AdaxGW is the perfect platform for ASN, GAN, UMA access concentrators and Femtocell and Security gateways.

The AdaxGW is a single software image configurable and reconfigurable to meet any requirement for today's emerging All-IP Network. It supports legacy SS7 connections to any SIGTRAN Ethernet connection and ATM-IP and I-TDM* interworking delivers VoIP for Access Concentration with Media Conversion providing a solid foundation for user and control plane applications.

AdaxGW Features

- Long-haul circuit replacement
- IP enables any legacy node
- Interworking to legacy ATM core networks
- Offers enhanced routing via GTT
- Transitional node for NGN STP replacement
- Provides Geographical Redundancy
- Supports CIC-based routing for multiple IP switches
- Multiple simultaneous network presences
- High Availability (HA) or Simplex solutions

Cost of Ownership Benefits

- Integrated to your platform of choice: rackmount system, cPCI, ATCA or proprietary blades, or ProcessorAMC
- One software image supports multiple configurations
- One management interface for all configurations
- Re-configurable & re-deployable
- Unparalleled scalability and flexibility to protect investment in both Legacy and IP networks

Technical Benefits

- SS7 & SIGTRAN protocols including M2PA, M2UA, M3UA and SUA
- SS7/IP and IP/IP interworking
- ATM-IP interworking
- ATM Interworking in 3 different modes:
 - IP over AAL5
 - AALx to UDP/IP
 - GTP-U UDP/IP (3GPP Standard 29.060)
 - ATM - Ethernet
 - Ethernet - ATM
 - Ethernet - Ethernet
- All Standard I/Fs: T1/E1 LSLs, Annex A HSLs, ATM T1/E1, OC3, OC12, GbE
- ANSI, ITU, UK, Chinese & Japanese national variants
- Telcordia and NEBS-3 certifications

*Future Release

AdaxGW Configuration Options

The AdaxGW software image can easily be integrated to your platform of choice: ATCA, cPCI, or proprietary blade, or ProcessorAMC. A fully integrated 2U ATCA rackmount system is also available. This allows the AdaxGW to blend seamlessly into your application environment.

- AdaxSG (Signaling Gateway) Configuration: A Highly-Available Signaling Gateway with legacy support for SS7 LSLs, Annex A and ATM HSLs connections allows full value to be extracted from existing equipment ensuring that no node will be left behind. With options for SS7/IP switching, routing, tunneling and backhaul, the AdaxSG provides a simple and straightforward migration of existing SS7 nodes to IP transport. The AdaxSG utilizes SIGTRAN protocols including M2PA, M2UA, M3UA and SUA to perform the SS7/IP and IP/IP translation function in many different ways.
- AdaxMC (Media Converter) Configuration: On the User Plane all technologies are using UDP/IP to carry voice and data including RTP. Interworking to Legacy ATM Core Networks and the ATM RAN is an important requirement in today's hybrid networks.

Changing network configurations is not a problem: via simple software upgrades and configurations the AdaxGW can meet the demands of your network, providing unparalleled flexibility and protecting your investments. Contact us to learn how we can make your implementation of LTE, NGMN & IMS networks successful.

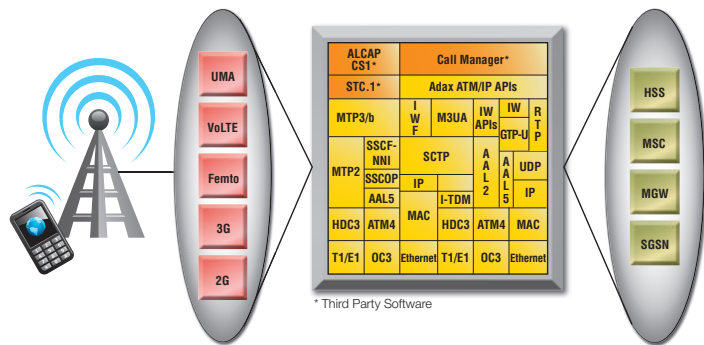

Border Gateway with ATM-IP IW

About Adax Specializing in Foundations for the All-IP Network, Adax offers a complete set of I/O controllers, blades & signaling gateways for SS7, ATM & IP packet processing, signaling & interworking. Adax high performance products meet today's challenges of I/O scalability, cost effectiveness and high availability in LTE, NGMN and IMS networks.



adax inc
 2900 Lakeshore Ave,
 Oakland, CA 94610, USA
 Tel: (510) 548 7047 Fax: (510) 548 5526
 Email: sales@adax.com Web: www.adax.com

adax europe ltd
 Reada Court, Vachel Road,
 Reading, Berkshire, RG1 1NY, UK
 Tel: +44 (0) 118 952 2800 Fax: +44 (0) 118 957 1530
 Email: sales@adax.co.uk Web: www.adax.com

adax china
 Unit B-4 27 floor,
 No. 888 Wan Hang Du Road
 Shanghai 200042, China
 Tel / Fax: +86 21 6386 8802
 Email: sales@adax.com Web: www.adax.com

Technical Specifications

Protocol and Standards Compliance

SS7

- SS7 MTP2: ITU-T Q.703, ETSI 300 008, 300 008-1, ANSI T1.111, TTC JT-Q.703, ITU Q.703 Annex A 1996, China SS7 YD/T 1125 – 2001
- SS7 MTP3: ITU-T Q.704, Q.707, ETSI 300 008, 300 008- 1, ANSI T1.111, Bellcore GR246, GR606, GR82
- SS7 SCCP: ANSI SCCP per T1.112 and Telcordia GR-246- CORE, with conformance testing per T1.235. ITU SCCP per Q.711 through Q.714, with conformance testing per Q.786c. ETSI SCCP per ETS 300 009
- MTP3b, Q.2210
- MTP3 transfer (NIF), MTP2 transfer (NIF)
- A, B, C, D, E, F Links

ATM

- ATM AAL2, ITU-T I.363.2
- ATM AAL5, ITU-T I.363.5
- SSCOP, Q.2110
- SSCF NNI, Q2140
- SSCF at UNI per Q.2130
- SSSC Layer Management Q.2144
- SSSAR/SSTED/SSADT, ITU-T I.366.1
- HSL over AAL5, Telcordia GR-2878-Core

SIGTRAN

- SCTP: RFC 4960
- M3UA: RFC 4666, Supports Chinese variant
- M2UA: RFC 3331
- M2PA: IETF Draft 7 - Draft 13, RFC 4165
- SUA: RFC 3868

SS7 Application Compatibility

- ISUP, TCAP, GSM MAP, IS-41

Interfaces Available

- T1/E1/J1 ports
- Drop & Insert on all channels
- ATM/HSL T1/E1 ports
- GbE ports
- OC3/STM-1/STS-3c ports
- OC12/STM-4/STS-12c ports
- RTM options available

Management

- AdaxGWManager GUI Interface (Web/Java)
- SNMP v2 for Traps and Statistics
- Telnet/Command Line Interface, password protection
- TFTP for software upgrade

Hardware Options

ATCA Blade

For details see separate Adax PacketRunner (APR) datasheet

Boxed Solution 2U Chassis

- 17.5" w x 12.5" d x 3.46" h
- DC power - 200W, hot swap, 1+1 redundant (with dual feed input), 250W optional
- AC power - 200W, hot-swap, 1+1 redundant (available with standard single or optional dual feed input), 250W optional

Designed to Meet

- NEBS-3, FCC class A (AC/DC)
- for Electrical & Safety standards compliance see separate datasheets for the Adax boards.

Environmental Conditions

- Operating -5°C to 55°C
- Relative Humidity 5% to 90%
- Storage -40°C to 70°C

All specifications are subject to change without notice.

AdaxGW 0511/08